



# OWNER'S MANUAL

## FLETCHER 2200™ PROFESSIONAL MAT CUTTER



**German**      **Page**      **19**

**French**      **Page**      **37**

**Spanish**      **Page**      **55**

FORM 122003

Ver. 3.16.4



**For sales, service and spare parts**

APM Mouldings 120-130 Bolinda Rd Campbellfield, VIC 3061  
Ph: 03 8301 9199 | Fax 03 9357 4077 | Email [apmoffice@chamton.com](mailto:apmoffice@chamton.com) | [www.apm-mouldings.com.au](http://www.apm-mouldings.com.au)

Australian Owned Family Company | Quality Moulding Manufacturers and Distributors

# TABLE OF CONTENTS

INTRODUCTION	3
WARRANTY	3
COMPONENTS	4
SET UP	5
HOW TO CUT MATS	6
SINGLE OPENING	6
V-GROOVE	7
DOUBLE MAT	7
MULTI-ANGLE MAT	11
OPTIONS	8
MEASURING STOPS	8
MAT CLAMP LIFTERS	8
RIGHT SQUARING ARM	9
BASE EXTENSION	10
ANGLE MAT GUIDE	11
ADJUSTMENTS	12
SQUARE MAT GUIDE	12
ADJUST CUTTING HEAD	12
MAINTENANCE	13
TROUBLESHOOTING GUIDE	14
PARTS LISTS	15
GERMAN	19
FRENCH	37
SPANISH	55

# INTRODUCTION

The Fletcher 2200™ Professional Mat Cutter is designed with the professional framer in mind and has evolved from the proven concepts of the Fletcher 2000® and Fletcher 2100® and incorporates many suggestions from the users of Fletcher-Terry framing products. Particular attention has been devoted to ergonomic design to provide comfort and ease of use. The Fletcher 2200 is available in imperial (40", 48" and 60") and metric (1.0m, 1.2m and 1.5m) versions.

The **Cutting Head** incorporates both bevel and straight cutting with comfort designed into both pivots. The straight (sizing) side uses a blade and magazine that cuts materials such as foamboard and gatorfoam® up to a nominal 1/2" (12mm) thick. Both magazines permit blade changing away from the **Cutting Head** minimizing exposure to the hazard of handling sharp blades. A unique **Sight Gage** on the **Cutting Head** provides precise control of over/under cuts when using pencil lines on the back of the mat.

The **Cutting Head** is fitted to a polished **Shaft** minimizing wear and "hooking". Adjustments are available so the framer can maintain the close fit in spite of heavy usage.

The usefulness of the popular **Locator Pin** has been improved by adding holes in the **Mat Guide Slide** to provide mat borders from 1-1/2" to 8" in 1/2" increments on the imperial version and 30mm to 210mm in 10mm increments on the metric version.

Options include: **Measuring Stops** assure minimum over cuts and under cuts; **Clamp Lifters** allow both hands to be free to place the mat in position; the **Right Squaring Arm** attaches to the base providing a rigid, accurate means of sizing mats; the **Angle Mat Guide** attaches to the **Mat Guide** creating a means of cutting angles other than 90 degrees in an opening and a **Base Plate Extension** permits mat borders up to 16" (405mm).

Multiple mats, V-grooves, and other creative mat designs can be easily and accurately produced on the Fletcher 2200.

## Product Warranty

The Fletcher-Terry Company warrants the Fletcher 2200 to be free from defects in parts and workmanship for (2) two years from the date of purchase. The Fletcher-Terry Company warrants that it will repair or replace any such defective machine or replace parts, providing the machine has been under normal use and service and the defective part or machine is returned to The Fletcher-Terry Company at the purchaser's expense. The Fletcher-Terry Company must authorize the return in writing. Proof of purchase must be submitted to validate warranty coverage.

The warranty is in lieu of all other agreements and warranties expressed or implied. THE FLETCHER-TERRY COMPANY DOES HEREBY EXPRESSLY DISCLAIM ANY WARRANTIES OF MERCHANTABILITY OR FITNESS FOR A PARTICULAR PURPOSE. The Fletcher-Terry Company does not authorize any company employee or representative to assume for it any other liability than that set forth in this Product Warranty. The Fletcher-Terry Company shall not be liable for any damages or losses, whether incidental or consequential or direct or indirect, arising out of the use or abuse of this machine. In any event, THE PURCHASER'S SOLE AND EXCLUSIVE REMEDY UNDER THIS OR ANY OTHER WARRANTY IS LIMITED TO RETURN OF THE PURCHASE PRICE PAID FOR THIS MACHINE.

# COMPONENTS

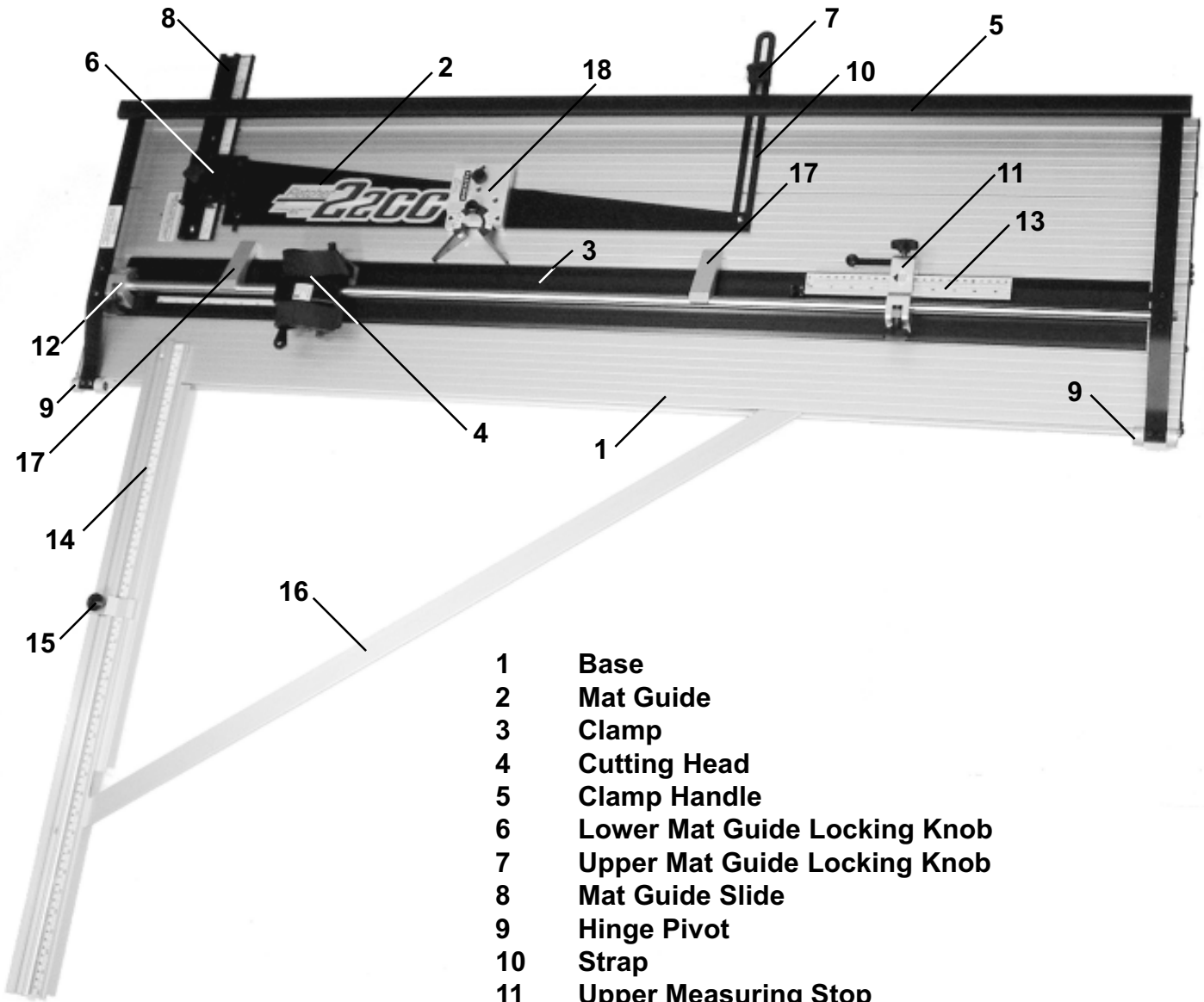

- 1 Base
- 2 Mat Guide
- 3 Clamp
- 4 Cutting Head
- 5 Clamp Handle
- 6 Lower Mat Guide Locking Knob
- 7 Upper Mat Guide Locking Knob
- 8 Mat Guide Slide
- 9 Hinge Pivot
- 10 Strap
- 11 Upper Measuring Stop
- 12 Lower Measuring Stop
- 13 Upper Stop Scale
- 14 Right Squaring Arm
- 15 Right Squaring Arm Stop
- 16 Right Squaring Arm Brace
- 17 Squaring Fixture
- 18 Angle Mat Guide

# SET UP

Place nine self adhesive rubber bumpers from the parts bag equally spaced on the bottom of the **Base** to prevent scratching a table top. Set the **Fletcher 2200** on a flat table with the **Clamp Handle** to the left.



## MAT BLADES

The bevel cutting side of the **Cutting Head** accepts any of three different **Fletcher Mat Blades**. The 05-012 is .012" (.3mm) thick and is used for cutting regular mats. The 05-015 is .015" (.4mm) thick and is used for denser or thicker mats. The 05-016 is a single edge blade, beveled on one side only. It is used for very dense or thick mats and must be installed with the beveled edge away from the head.

The straight sizing blade on the right is the **Utility Blade**, 05-004, and is capable of cutting material up to a nominal 1/2" (12mm) thick. All blades except the 05-016 single edge blade can be reversed in their magazine to double the life of the blade, however, they must be inserted carefully to avoid damage.

1. Insert a **Blade (C)** in the bevel cutting **Magazine (A)** as shown in Figure 1. The **Blade Extension Screw (B)** should be adjusted so the **Blade (C)** penetrates about 1/3rd the thickness of a slip sheet under the mat being cut. The blade should always rest against the **Blade Extension Screw (B)**, and the **Magazine (A)** must be fully inserted in the **Cutting Head (D)**. Tighten its **Locking Knob (E)** firmly. See Figure 3.
2. Straight cutting (sizing) is done on the right side of the **Cutting Head (D)**. The **Magazine (F)** and **Utility Blade (G)**, (05-004), are shown in Figure 2. There are 4 possible depth positions for this blade, but only two are used as seen in Figures 2 and 2a. Figure 2a is the position for nominal 1/2" (12mm) material, while Figure 2 is for 2, 4, 6, and 8 ply mat board. The blade is held in place by a magnet. Insert the **Magazine (F)** to a stop in the **Cutting Head (D)** and tighten its **Locking Knob (K)**. See Figure 4.

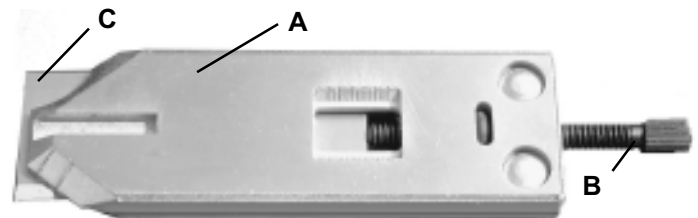

Figure 1

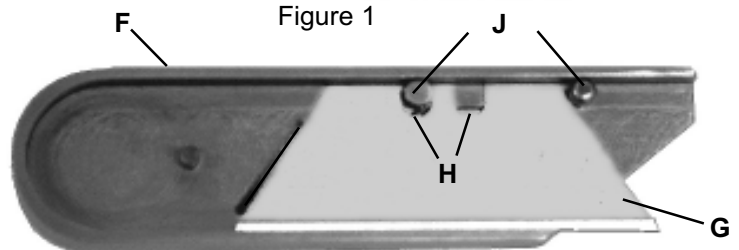

Figure 2

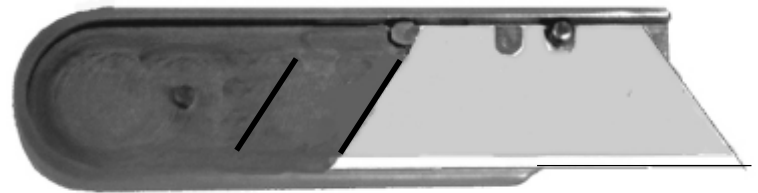

Figure 2a

3. The **Sight Gage (L)** shown in Figure 3 is used to control the start and end of cut when using pencil lines drawn on the back of the mat. It is held in place on the **Cutting Head** with a magnet and can be removed and set aside when not being used. The use of this feature is explained on the following page.

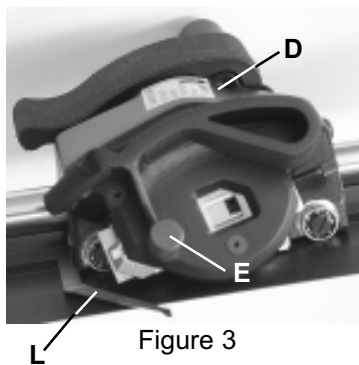

Figure 3

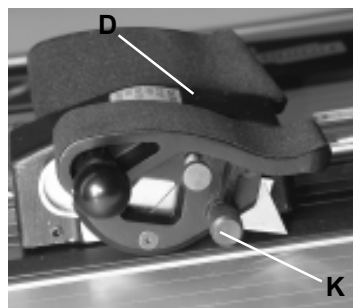

Figure 4

# HOW TO CUT MATS

## SINGLE OPENING

The most important requirement for cutting a good mat is a sharp blade. Mats are abrasive and will wear out a blade eventually. The value of a well cut mat is far greater than the cost of a blade.

1. Prepare a slip sheet about 8" (200mm) wide and 40" (1016mm) long and place it under the **Mat Clamp (A)**. Use a piece of mat the same thickness as the one you will be cutting and lay it on top of the slip sheet. Press down on the **Handle** lightly to hold the mat in place. Slide the **Cutting Head (B)** beyond the edge of the mat and rotate the **Pivot** to insert the blade in the slip sheet. You can now observe the tip of the blade which should penetrate about 1/3 the thickness of the slip sheet. Mats of a different thickness will require retesting and adjustment of the blade extension. If you press down on the **Handle** with too much force, the **Mat Clamp** will bow upward in the center. This increases the distance between the blade tip and the mat at the center of the cut and may prevent full penetration of the blade when cutting a large mat. Use only enough downward pressure to lock the mat in place so it does not move. See Figure 5.

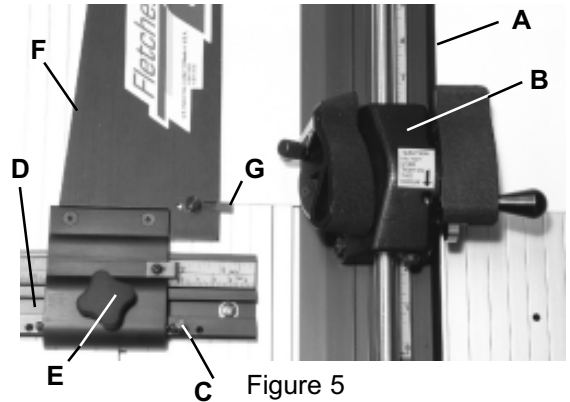
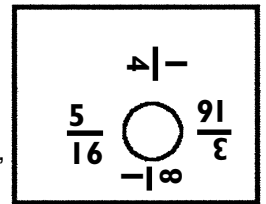

Figure 5

2. The **Locator Pin (C)** provides accurate and repeatable settings for mat borders from 1-1/2" to 8" in increments of 1/2" for the imperial measurement version. The **Mat Gauge** adds 1/8", 3/16", 1/4" or 5/16" to the **Locator Pin** positions. The metric version has **Locator Pin** holes for mat borders from 30mm to 210mm in increments of 10mm. The metric **Mat Gauge** adds 3mm, 4mm, 5mm, or 7mm to the **Locator Pin** setting. The ability to repeat settings accurately is an advantage over reading a scale, especially when producing multiple mats.



3. For example, cut a single mat with a 3" (70mm) border and a V-groove at 2-1/2" (60mm). Insert the **Locator Pin** in the third hole from the right in the **Mat Guide Slide (D)** and slide the **Mat Guide (F)** to the right to contact the **Locator Pin**. Tighten both the **Lower Mat Guide Locking Knob (E)** and the **Upper Mat Guide Locking Knob** shown as no. 7 on page 4. Always tighten them in this sequence, lower before upper. Place a pre-sized 16" X 20" (400mm X 500mm) matboard upside down and slide it to the left against the **Mat Guide** and downward against the **Mat Stop (G)**. Lower the **Clamp Handle**. Use a sharp pencil (never ink) and draw a line along the left edge of the **Clamp** starting and stopping about 1/2" (13mm) from the edges of the mat. Rotate the mat 90 degrees and repeat drawing the pencil line until all four side have been penciled. Also pencil the mat where the border will join the "fall-out" at one side so you can maintain the same orientation later during V-grooving or cutting Double Mats.

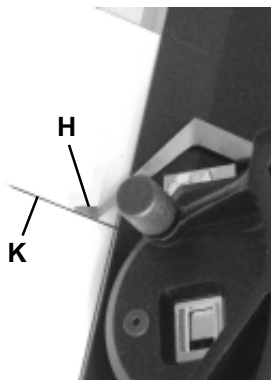

Figure 6

4. Press down on the **Clamp Handle** and pivot the bevel cutting blade into the mat for the start of a cut. Figure 6 shows the starting position by lining up the **Sight Gauge (H)** with the upper pencil line (K).

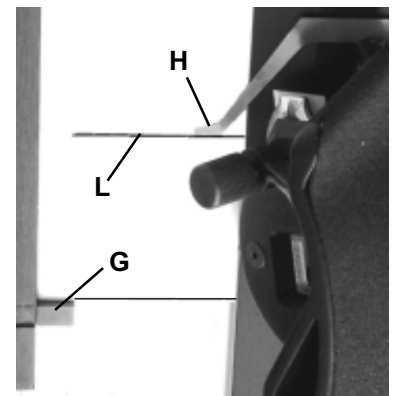

Figure 7

5. Make the cut, stopping when the **Sight Gauge (H)** reaches the lower pencil line (L). This is the end of cut and is shown in Figure 7.
6. Raise the Handle, rotate the mat 90 degrees and repeat the next cut, starting and stopping at the cross pencil lines as before. Remove the mat and examine the top side. There should be a barely perceptible overcut at each corner to assure the "fall-out" is cut free of the mat. Excessive overcuts or undercuts should be corrected by your judgement in lining up the **Sight Gauge** with the pencil lines as well as the blade extension.

## V-GROOVE

If you wish to add a V-groove before cutting the opening on page 6, follow this procedure.

1. **CAUTION:** Loosen the **Mat Stop** and slide it to the left so it does not protrude from the **Mat Guide**. Re-tighten its **Locking Knob**. Remove the **Locator Pin**, loosen the two **Mat Guide Locking Knobs** and slide the **Mat Guide** all the way to the right against the **CLAMP**. Place the **Locator Pin** in the hole nearest the hex screw on the left side of the **Mat Guide** base and slide the **Mat Guide** back to the left so the hex screw rests against the **Locator Pin**. Tighten the **Mat Guide Locking Knobs**. This instruction applies to both the imperial and metric versions.
2. Remove the **Sight Gage**. Place the “fall-out”, right side up, against the **Mat Guide**. Start with the **Cutting Head** well above the upper edge of the mat. Rotate the bevel cutting pivot and pull it at a steady speed until it has trimmed a sliver from the edge of the “fall-out”. Repeat this procedure on the other three edges. Remove the scrap strip after each cut to prevent interference when positioning the mat against the **Mat Guide**. If the blade projects too far from the magazine it may touch the **Mat Guide** which will damage the blade.
3. Place the “fall-out” upside down on a flat table surface. Lay the mat over the “fall-out”, oriented as it was in step 3 on the previous page. Tape the four cuts with non-removable tape. Turn the mat over and inspect the V-groove.
4. Remove the **Locator Pin**, loosen the **Mat Guide Locking Knobs**, slide the **Mat Guide** to the left and insert the **Locator Pin** in the fourth hole from the right, the 3” (70mm) hole. Slide the **Mat Guide** against the **Locator Pin** and tighten its two **Locking Knobs**.
5. Proceed to cut out the opening as described in steps 4 and 5 on the previous page. The result will be a mat with a V-groove 1/2” (10mm) outside an opening with a 3” (70mm) border.
6. The width of the V-groove can be adjusted slightly by turning the hex screw on the left side of the base of the **Mat Guide** with the hex wrench provided in the parts bag. Turning the hex screw clockwise will increase the width of the V-groove, but increasing it too much will cause the blade to cut all the way through the mat resulting in a gap, not a groove. Turning the screw counter-clockwise will decrease the width of the V-groove. Too much of this adjustment, however, may cause the blade to hit the **Mat Guide**.

## DOUBLE MAT

A double mat with a V-groove is a very attractive and popular mat, and is easily produced on the Fletcher 2200 Professional Mat Cutting System.

1. Prepare a color contrasting mat to become the liner. Size it 1/8” (3mm) smaller in both width and length than the mat you used in the previous example.
2. Lay the “fall-out” you produced in step 5 above, upside down on a clean flat surface. Place the V-grooved mat over it so the “fall-out” fits into its opening. Using an adhesive transfer type device, roll one or two strips of adhesive in the four borders of the mat. Place two strips of adhesive on the “fall-out,” but stay well away from the edge. Place the liner mat face down over the first mat. Be sure all four of its edges are inside the edges of the top mat. The entire assembly is now glued together.
3. The **Mat Gage** will increase the **Mat Guide** setting when the **Locator Pin** is inserted through the **Mat Gage** then the **Mat Guide Slide**. Place the **Locator Pin** through the **Mat Gage** and into the 3” (70mm) hole as before. You will notice the **Mat Gage** can be rotated. Turn it so the side labelled 3/16” (5mm) is to the left. Move the **Mat Guide** into contact with the **Mat Gage** and tighten the **Locking Knobs**.
4. Place the assembled mat upside down under the **Clamp** and against the **Mat Guide** and **Mat Stop**. Make four pencil lines as you did when you produced the first mat. Proceed to bevel cut all four borders as before.
5. The double “fall-out” is now discarded and you have made a double mat with V-groove. Notice the exposed liner is 3/16” (5mm) wide and uniform on all four sides.

# OPTIONS

## MEASURING STOPS

The **Measuring Stops** are more than an aid to production of common size mats. They are quick to use and eliminate the time consuming technique of drawing lines on the back of the mat. In addition, they assure minimum overcuts and can prevent undercuts. The **Stop Screws** are adjusted in the following manner and need not be changed unless the blade extension is changed for different thickness mats.

1. Insert the **Locator Pin** for the desired border width and place a mat under the **Clamp** in the usual position for bevel cutting. CAUTION: Be sure the lower left edge of the mat rests against the **Mat Stop (N)** in Figure 11. Make the four pencil lines as described previously.
2. Set the **Upper Measuring Stop Scale (A)** (Figure 8) to the same border width as the **Locator Pin** and lock it in place with **Locking Knob B**.
3. Slide the **Upper Measuring Stop (D)** toward the mat while holding the **Spring Button (C)** down on the slip sheet. When the **Spring Button** touches the upper edge of the mat, lock the **Upper Measuring Stop** in position with its **Locking Knob (E)**.
4. Move the **Cutting Head** against the **Stop Screw (F)** on the **Upper Measuring Stop**. Rotate the bevel cutting blade until it touches the mat. It should contact the mat about 1/8" (3mm) beyond the upper horizontal pencil line. If not, turn the **Stop Screw** in or out until the blade is in the correct position. Lock the **Stop Screw** in place with its **Jam Nut (G)**.

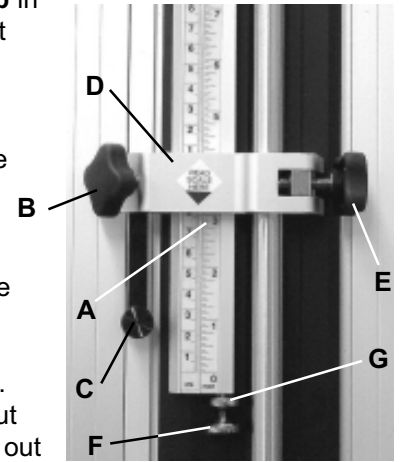

Figure 8

5. Set the **Lower Measuring Stop (H)** at the same border width on its scale mounted on the top of the **Clamp**. See Figure 9. Starting at the upper position, insert the blade through the mat. The right hand scribed line on the **Magazine (L)**, in Figure 10, should line up with the pencil line and the **Sight Gauge** should also be in line with the pencil line. Now pull the **Cutting Head** toward the **Lower Measuring Stop** in the usual way. It should hit the **Lower Measuring Stop** when the blade has passed the lower horizontal line about 1/8" (3mm). The left scribed line (**M**) on the **Magazine** should now be in line with the pencil line, see Figure 11. If necessary, adjust the **Stop Screw (J)** on the **Lower Measuring Stop** to achieve the 1/8" (3mm) dimension. Lock the **Stop Screw (J)** in place by tightening its **Jam Nut (K)**.

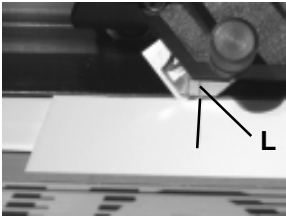

Figure 10

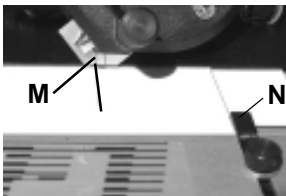

Figure 11

6. Proceed to cut out a complete mat. Cut both opposite sides first, then move the **Upper Measuring Stop** to the top edge of the mat and cut the other two sides. Examine the corners of the bevel cuts on the front side. The "fall-out" must be completely free and the overcut barely visible. If not, adjust the appropriate **Stop Screws**. Too much overcut requires moving the **Stop Screw** toward the **Cutting Head**. Incomplete corner separation (undercut) requires moving the **Stop Screw** away from the **Cutting Head**. Re-adjustment of the stop screws is not required unless cutting a mat of different thickness.

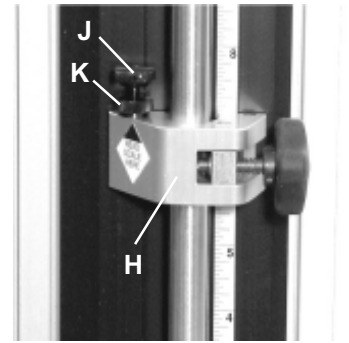
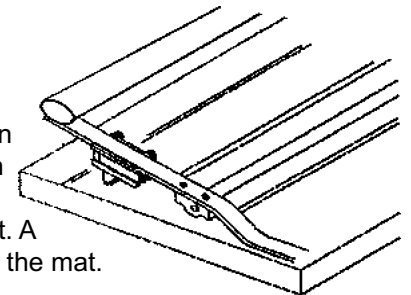

Figure 9

## MAT CLAMP LIFTERS



Two **Mat Clamp Lifters**, (one shown at the left), are provided as an option. Each is mounted on the underside of a **Hinge Bracket** with the spring loaded roller resting on the **Base** as shown at the right. This allows both hands to be free to position the slip sheet and mat. A slight downward pressure on the **Handle** lowers the **Mat Clamp** to the mat.





## RIGHT SQUARING ARM

This option will speed up the production of mats by giving you exact down-sizing of matboard. Its sturdy construction and bracing will assure accurate sizes and 90 degree corners, so important to fine mat work.

Tools required: phillips screwdriver, 5/32" hex wrench, and adjustable wrench.

You will receive the **Right Squaring Arm** components disassembled into three parts, the **Right Squaring Arm (A)** with an inch/metric scale, the **Angle Brace (B)**, a **Squaring Arm Stop (C)** and fasteners. See Figure 12.

1. The Fletcher 2200 should be resting on a flat surface large enough to provide support for the **Right Squaring Arm**. You will see a hole in the **Base** about 5" from the near end (**D**). Assemble the flat head screw, from the parts bag, through the **Right Squaring Arm** and the **Base**. Place the washer, lock washer, and hex nut on the screw from beneath the **Base** and tighten.
2. On the right edge of the **Base** about 40" from the near end, you will find a button head screw (**E**) which is threaded into a nut in the **Base**. Remove the screw with the 5/32" hex wrench. Leave the nut in the **Base**. At the upper end of the **Angle Brace**, you will see a hole in a bracket. Connect this bracket to the edge of the **Base** using the button head screw and nut. Tighten the screw only slightly.

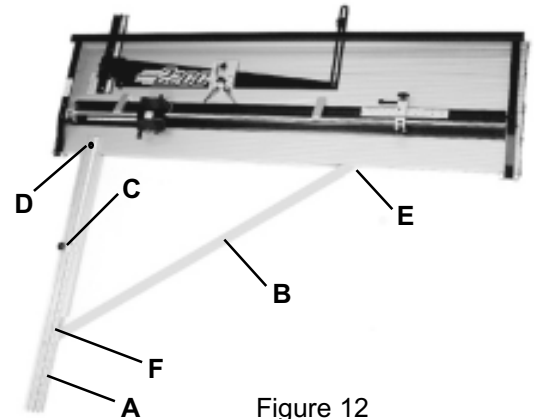

Figure 12

3. Remove the flat head screw and eccentric hex nut from the parts bag. Assemble this screw and eccentric nut through the **Right Squaring Arm** and the hole in the end of the **Angle Brace (B)**. Be sure the eccentric nut (**F**) is fully seated in the 7/16" hole in the **Angle Brace**. Leave it slightly loose.
4. Turn the hex eccentric nut with your fingers. You will notice the **Right Squaring Arm** move up and down with respect to the **Angle Brace**. At about halfway in this motion, tighten the flat head screw while holding the eccentric nut.

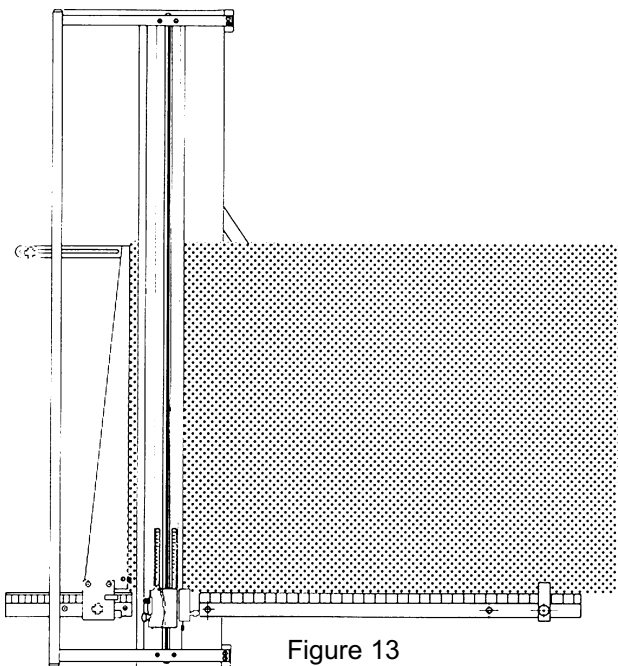

Figure 13

5. The **Mat Guide** should be locked in position on the **Mat Guide Slide**. Place a full size mat (32x40) horizontally on the **Base** with the lower edge resting against the **Squaring Arm**. Note, it is not placed on top of the scale. Slide the mat to the left so it touches the **Mat Guide** evenly along the full length of the **Mat Guide**. You will note the mat is probably not in contact along the full length of the **Right Squaring Arm**. Slide the upper end of the **Angle Brace**, under the button head screw, until the mat is in full contact with both the **Mat Guide** and **Right Squaring Arm**. See Figure 13.
6. Slightly loosen the flat head screw at the joint of the **Squaring Arm** and **Angle Brace**. While holding the screw with a screwdriver, rotate the eccentric nut slowly until the bottom edge of the mat is in contact along the full length of the **Squaring Arm** and the **Mat Guide**. Now, tighten the flat head screw without letting the eccentric nut turn. Also tighten the nut under the **Base** at the end of the **Right Squaring Arm** and the button head screw which holds the **Angle Brace** to the right side of the **Base**.

If you are unable to obtain the square condition with this adjustment, slide the **Angle Brace** where it is attached with the button head screw and repeat the eccentric nut adjustment. Be sure all screws are well tightened and then re-check squareness by bringing the mat into contact with both the **Right Squaring Arm** and the **Mat Guide** at the same time.

- The scale in the **Right Squaring Arm** has pressure sensitive adhesive on the underside. Slide the scale out to the right several inches. Peel off 4" of the protective paper from the adhesive and slide the scale back to the left, but do not set the adhesive yet. See Figure 14.
- Draw a vertical line 3" from the left edge of a mat. Place the mat's lower edge against the **Right Squaring Arm** and slide it slowly to the left until it contacts the vertical blade (sizing blade) which should be rotated downward. The scale should now be positioned in its slide aligning the pencil mark with the 3" index on the scale. Press down on the right end of the scale so it adheres to the **Right Squaring Arm**. If it should ever be necessary to reposition this scale, it should be easy to pry up the adhered section and relocate the scale.

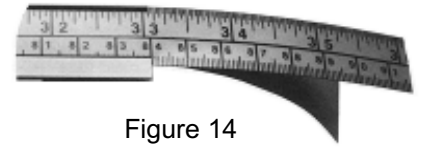

Figure 14

## BASE EXTENSION

- Remove the **Mat Guide (A)**, **Mat Guide Slide (B)** and the **Bracket (C)** on the left side of the **Base**. Set the fasteners aside to be used again.
- Remove both **End Caps (D)** from the machine and save. Set the screws aside to be used again.
- Three sets of screws and square nuts are provided. Only two sets will be required for 40" and 48" models. Insert button head screws through the holes on the left edge of the **Base** with the threads sticking out. Screw the square nuts on the screws only one or two turns. They must be very loose for now.
- Slide the optional **Base Extension** on the nuts. You will note the square nuts fit in a groove on the the right side of the **Base Extension**. Align both ends of the base members and tighten the screws and square nuts. You will use the hex wrench supplied with the machine.
- Assemble the new **End Caps** using the screws from the discarded ones and additional screws from the parts bag. Attach the three rubber buttons from the parts bag to the bottom ribs of the **Base Extension**.
- Install the new, longer **Mat Guide Slide** on the **Base**, using the fasteners from the old one. Slide the **Mat Guide** on the **Mat Guide Slide** and reinstall the **Bracket** on the left edge of the **Base Extension**. Square the machine as shown in the adjustments section of this Owner's Manual.
- A new, longer **Upper Measuring Stop Slide** is provided in case you are using the **Measuring Stop** option. Simply exchange it on the **Upper Measuring Stop**. Also, longer inch and metric scales are provided in this kit to replace those on top of the **Mat Clamp** to permit you to set the **Lower Measuring Stop** to larger mat border dimensions. If you wish to install these new scales, mark the **Mat Clamp** at the zero position before removing the old scale. In this way you can easily locate the new scale.
- The new **Base Extension** has a tapped hole in line with the **Mat Guide Locking Strap**. You may wish to mount the **Upper Locking Knob** on top of the **Base Extension**. This will accommodate the same mat border dimensions as the standard machine. When larger mat borders are required, the **Upper Locking Knob** can be moved to the **Bracket** on the left side of the **Base Extension**.

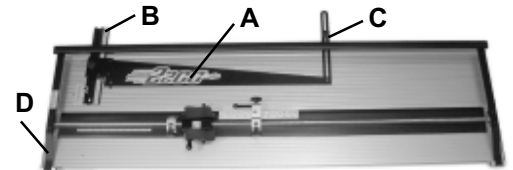

Figure 15

# ADJUSTMENTS

## SQUARE THE MAT GUIDE

1. Slide the **Mat Guide** to the right until it contacts the **Locator Pin (A)** in the 2" (50mm) hole, and tighten the **Lower (B)**, then **Upper Locking Knobs** on the **Mat Guide**. See Figure 17.
2. Place an 8" x 10" matboard under the **Clamp** in full contact with the **Mat Guide** at the lower part of the **Mat Guide**.
3. Make a bevel cut about 1" (25 mm) long near the lower edge of the mat. Move the mat to the top of the **Mat Guide** and make another cut starting beyond the first cut and running into it. When the **Mat Guide** is properly squared, these two cuts will coincide and appear to be a single cut.
4. If the two cuts are not in line, the **Mat Guide** must be squared as follows: Loosen the left-hand (**C**) and right-hand (**D**) screws on the **Mat Guide Slide (E)**. Loosen both the **Lower Locking Knob (B)** and **Upper Locking Knobs (F)**. Place the two **Squaring Fixtures (G)** (from the parts bag) on the steel **Shaft**, one near the bottom end of the **Mat Guide** and the other near the top, as in Figure 18. Remove the **Locator Pin (A)** and use your left hand to slide the **Mat Guide** firmly against both **Squaring Fixtures**. While keeping pressure against the **Squaring Fixtures** tighten the **Lower Locking Knob (B)** then the left hand screw (**C**), followed by the right hand screw (**D**) on the **Mat Guide Slide (E)**. Be sure to leave the **Upper Locking Knob (F)** loose during this adjustment. Retest for squareness as in item 3 above.

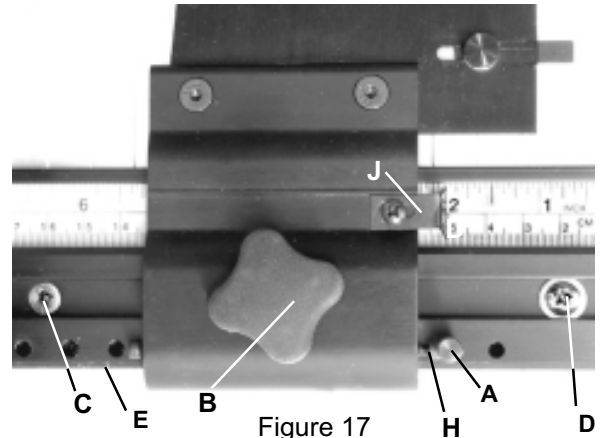

Figure 17

Remove the **Locator Pin (A)** and use your left hand to slide the **Mat Guide** firmly against both **Squaring Fixtures**. While keeping pressure against the **Squaring Fixtures** tighten the **Lower Locking Knob (B)** then the left hand screw (**C**), followed by the right hand screw (**D**) on the **Mat Guide Slide (E)**. Be sure to leave the **Upper Locking Knob (F)** loose during this adjustment. Retest for squareness as in item 3 above.

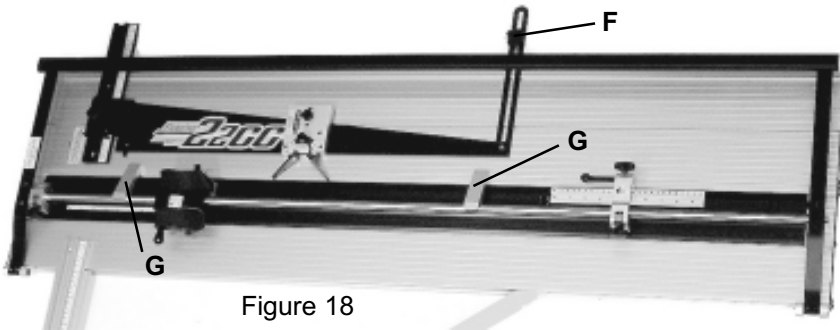

Figure 18

5. Always tighten the **Lower Mat Guide Locking Knob (B)** before the **Upper Locking Knob (F)**. It is the lower one which aligns the **Mat Guide**. The upper one simply anchors the upper end of the **Mat Guide**.
6. Make a bevel cut and measure its distance from the left side of the mat. If it is not exactly 2" (50mm), turn the hex screw (**H**) clockwise to decrease or counterclockwise to increase the mat border. Then, re-position the **Index (J)** to read 2" (50mm) on the scale.

## CUTTING HEAD ADJUSTMENTS

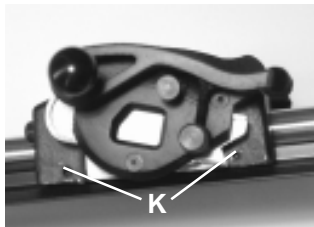

Figure 19

1. Periodically adjust the **Cutting Head** to assure a close fit on the **Shaft**. Slowly tighten either of the set screws (**K**) while sliding the **Cutting Head** back and forth on the **Shaft**. When you feel a drag, loosen the screw until the **Cutting Head** slides freely. Repeat with the other set screw (**K**).
2. Adjust set screw (**L**) in the same manner. Be sure to slide the **Cutting Head** while tightening the set screw so you do not over-tighten and cause damage.

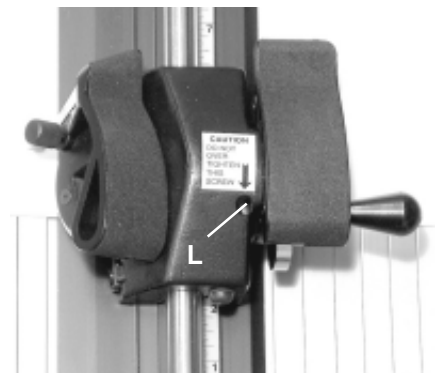

Figure 20

# MAINTENANCE

Maintenance of your FLETCHER 2200 PROFESSIONAL MAT CUTTER is mostly a matter of cleanliness.

1. Keep a dry, lint free cloth near the machine. Wipe the **Shaft** and **Mat Clamp** daily and frequently during use to remove loose paper particles, dust, and other foreign matter. DO NOT USE OIL OR WAX. Cover the machine with a dust cover when not in use.
2. Periodically check the squareness and accuracy of sizing cuts, **Mat Guide** squareness and dimensions of mat borders. If corrections are required, follow the procedures outlined in the **ADJUSTMENTS** section. The frequency of inspection depends upon how many people are using the cutter and the care it is given. If set up properly and the mounting and adjustment screws are not changed, it will produce excellent results indefinitely.
3. If the **Cutting Head** makes a rumbling noise it is caused by paper debris on the **Mat Clamp** or **Ball Bearings**. First, wipe the top of the **Mat Clamp** thoroughly. Slightly loosen the set screw (**L**) shown on the previous page in Figure 20. Tack down one end of a 6" strip of tape on the top of the **Mat Clamp** in the path of the **Roller Bearing** and fold the tape back away from the **Cutting Head** so the glue side of the tape is facing up. Slowly slide the **Cutting Head** over the tape. Debris will be transferred to the tape which can be discarded. Repeat this procedure for the other **Ball Bearing** track. Be sure to re-adjust the set screw (**L**) as described on the prior page.
4. Both the bevel and straight pivot heads on the **Cutting Head** should rotate freely, but without excessive play. The **Pivot Screw**, accessible after removing the Magazines, must be tight. **Shim Washers** are available in four different thicknesses from .002" to .006" (.051mm to .152mm). Choose a combination of shims and insert the **Pivot Screw** through them before tightening. These washers are identified as Ref. number 5 in the **Cutting Head Parts List**.
5. If it is ever necessary to remove the **Cutting Head**, follow this procedure:
  - a. Remove both blade **Magazines**. Remove the hex head bolt (**A**) from the lower end of the **Shaft**. Be sure to keep the spring washer with the bolt. See Figure 21.
  - b. Remove the two button head hex screws (**B**) from the lower **Hinge Bracket** using the hex wrench provided.
  - c. Slip the **Shaft Bracket** off the **Shaft**. Lift the **Clamp Handle** just enough to allow the **Shaft Bracket** to be removed.
  - d. Slide the **Cutting Head** off the shaft. Do not lift the **Clamp Handle** any higher than clearance requires. Hold your hand beneath the **Cutting Head** to prevent the **Ball Bearing (C)** from falling to the floor. Re-assemble the **Cutting Head** in the reverse order.

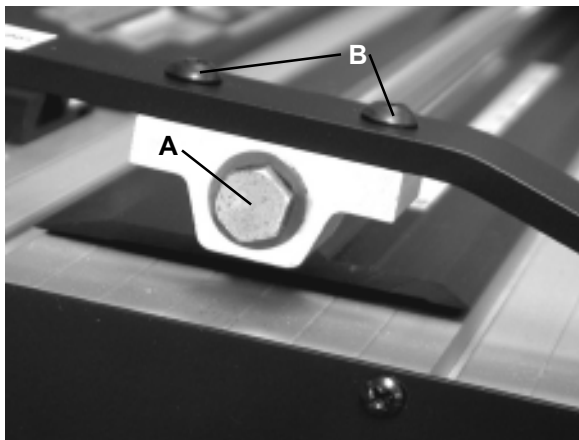

Figure 21

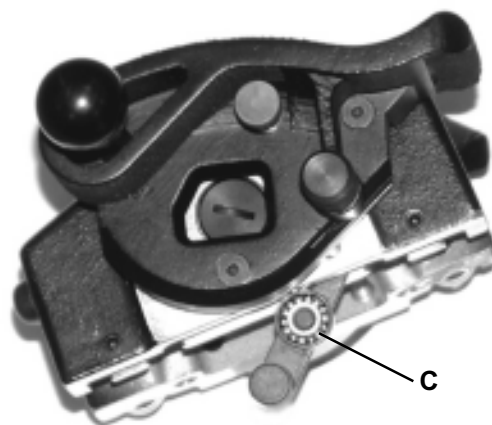

Figure 22

# TROUBLESHOOTING GUIDE

PROBLEM	POSSIBLE CAUSE	CORRECTION	REFERENCE
Frayed bevel cuts	Dull blade	Change to a new blade	SET UP
	Worn out slip sheet	Use fresh slip sheet	HOW TO CUT MATS
Not cutting through the mat	Blade projection	Extend projection of blade	SET UP
	Worn or broken blade	Replace blade	SET UP
	Pressing too hard on the handle	Ease up on pressure	HOW TO CUT MATS
Excessive overcut	Blade projection	Adjust projection of blade	SET UP
	Measuring Stop	Adjust Measuring Stop	HOW TO CUT MATS
Undercut	Blade projection	Adjust projection of blade	SET UP
	Measuring Stop	Adjust Measuring Stop	HOW TO CUT MATS
Head binds	Head Bearings	Adjust Head Bearings	MAINTENANCE
Head too loose	Head Bearings	Adjust Head Bearings	MAINTENANCE
"Hook" in cuts	Blade projects too far	Adjust projection of blade	SET UP
	Head loose	Adjust Head Bearings	MAINTENANCE
Head "rumbles"	Roller Bearing path dirty	Clean Mat Clamp	MAINTENANCE
	Roller Bearings dirty	Remove Head and clean Bearings	MAINTENANCE
		Use tape to remove foreign material	MAINTENANCE

FOR ASSISTANCE, CONTACT THE FLETCHER-TERRY COMPANY CUSTOMER SERVICE DEPARTMENT AT 800.843.3826 (U.S./CANADA) OR [customerservice@fletcher-terry.com](mailto:customerservice@fletcher-terry.com).

# PARTS LISTS

Ref.	Part No.	Description	Quantity
1	12-500	Base R.H. 40" Capacity	1
1	12-001	Bass R.H. 48" Capacity	1
1	12-116	Base R.H. 60" Capacity	1
2	12-501	Base L.H. 40" Capacity	1
2	12-502	Base L.H. 48" Capacity	1
2	12-503	Base L.H. 60" Capacity	1
3	12-504	Mat Guide Slide Inch	1
3	12-554	Mat Guide Slide Metric	1
4	12-567	Mat Guide Slide Scale	1
5	12-583	Mat Guide Assy. 40" & 48"	1
5	12-584	Mat Guide Assy. 60" Capacity	1
6	12-507	Locking Strap	1
7	12-585	Handle 40" Capacity	1
7	12-568	Handle 48" Capacity	1
7	12-580	Handle 60" Capacity	1
8	12-569	Handle End Cap	2
9	12-570	Hinge Bracket	2
10	12-009	Hinge	2
11	12-010	Pivot Shaft	2
12	12-011	Shaft Bracket	2
13	12-012	Shoulder Screw	2
14	12-013	Spring Washer	2
15	12-014	Locator Pin	2
16	12-015	Mat Gage Imperial	1
16	12-550	Mat Gage Metric	1
17	12-509	Base Nut	2
18	12-586	Cutting Head Assembly	1
19	12-511	Clamp Assy. 40"	1
19	12-512	Clamp Assy. 48"	1
19	12-513	Clamp Assy. 60"	1
20	12-314	Button Head Screw	9
21	12-314	Button Head Screw	1
22	12-021	Button Head Cap Screw	6
23	12-022	Washer	2
24	12-023	Lock Nut	2
25	12-312	Flat Head Screw	1
26	12-571	Washer (Black)	1
27	12-573	Inch Scale	1
28	12-574	Metric Scale	1
29	12-035	Button	12
30	12-039	Scale Indicator	1
31	12-293	Pan Head Screw	1

Ref.	Part No.	Description	Quantity
32	12-041	End Cap	2
33	12-042	Mat Stop Knob	1
34	12-043	Washer	1
35	12-044	Mat Stop	1
36	12-244	Flat Head Screw	2
37	12-576	Comfort Knob	2
38	12-514	Key	1
39	12-049	Stop Screw	2
40	12-052	Wear Tape	5
41	12-053	Square Nut	9
42	12-054	End Cap Screw	20
43	12-056	Button Head Screw	4
44	12-318	Washer	1
45	12-125	Bracket	1
46	12-126	Flat Head Machine Screw	1
47	12-127	Lock Washer	1
48	12-128	Acorn Nut	1
49	12-543	Mat Guide Squaring Fixture	2

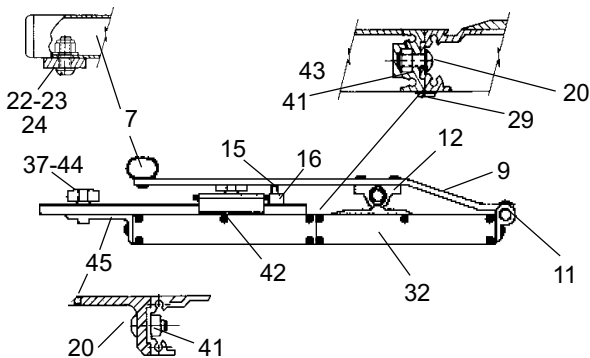
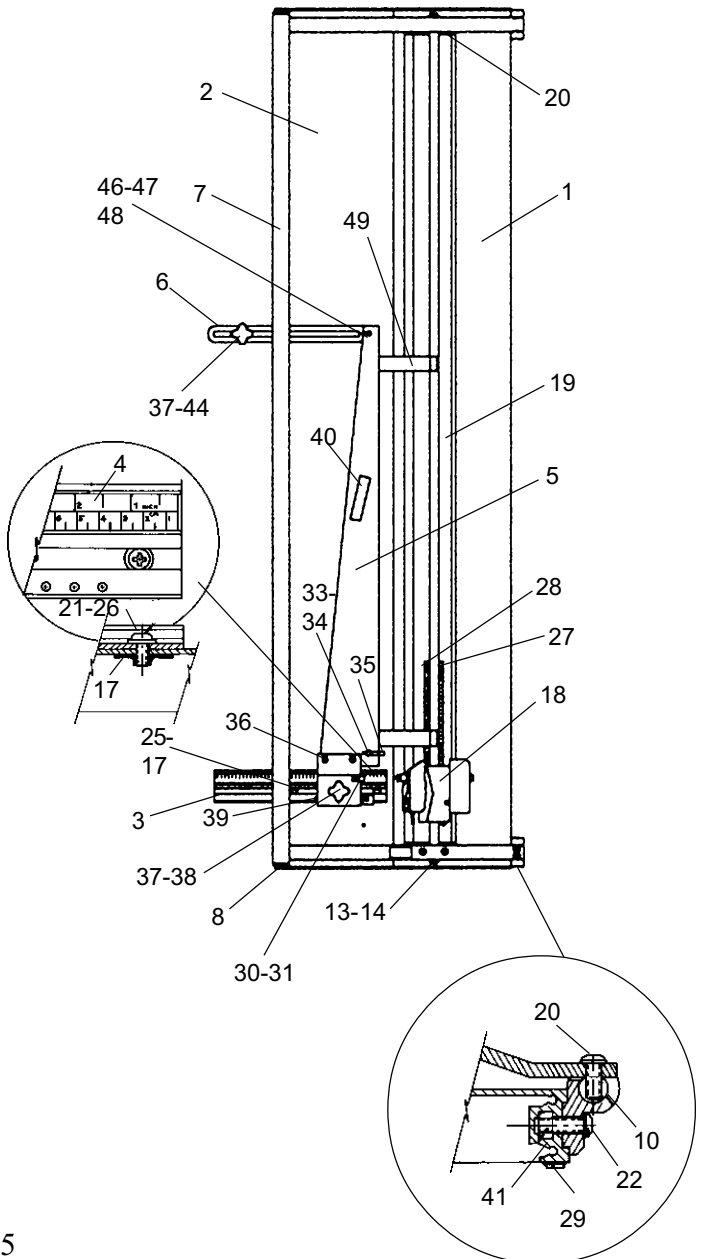

## CUTTING HEAD

Ref.	Part No.	Description	Quantity	Ref.	Part No.	Description	Quantity
1	12-572	Pivot Head Assembly (LH)	1	10	12-537	Shoulder Screw	2
2	12-530	Extension Spring	2	11	12-538	Bushing	2
3	12-588	Stainless Washer	2	12	12-591	Pivot Head Assembly (RH)	1
4	12-532	Pivot Screw	2	13	12-915	Knob (RH)	1
5	12-533	Shim Washer	4	14	12-542	Magazine Assembly (LH)	1
6	12-589	Comfort Grip (LH)	1	15	12-102	Pivot Arm	1
7	12-535	Knob (LH)	1	16	12-593	Magazine Assembly (RH)	1
8	12-590	Flat Head Cap Screw	5	17	12-241	Plastic Knob (RH)	1
9	12-073	Ball Bearing	3	18	12-242	Hex Stud	1
				19	12-243	Sight Gage	1
				20	12-592	Comfort Grip (RH)	1

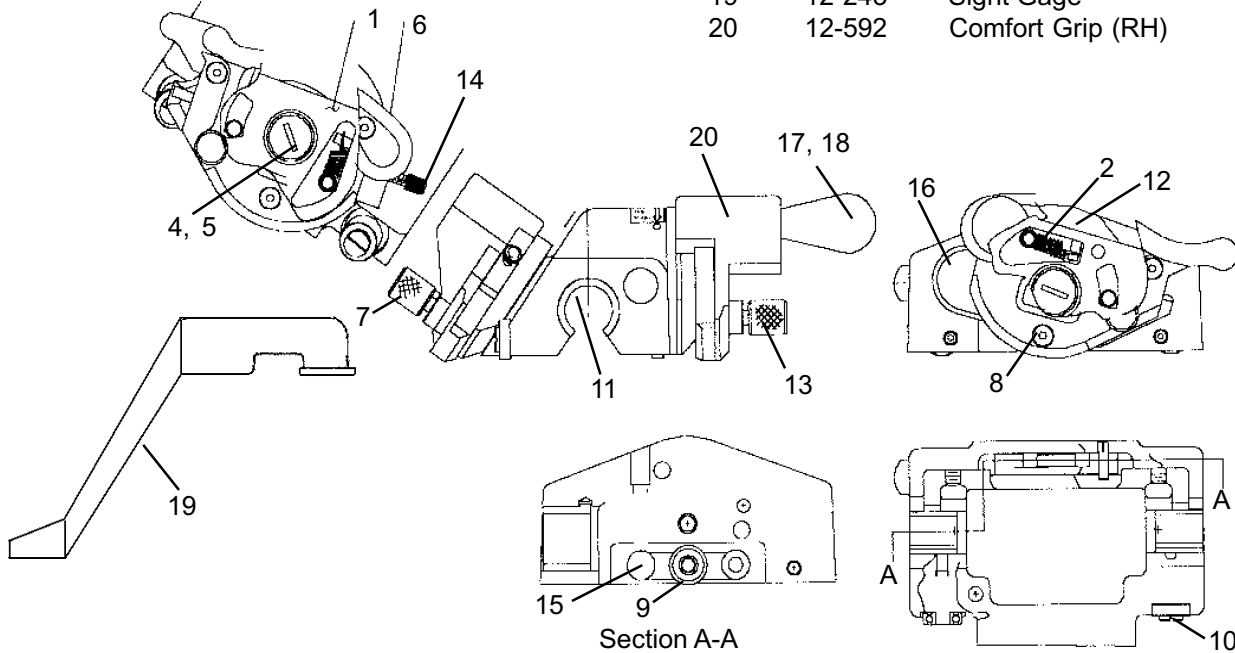

## RIGHT SQUARING ARM

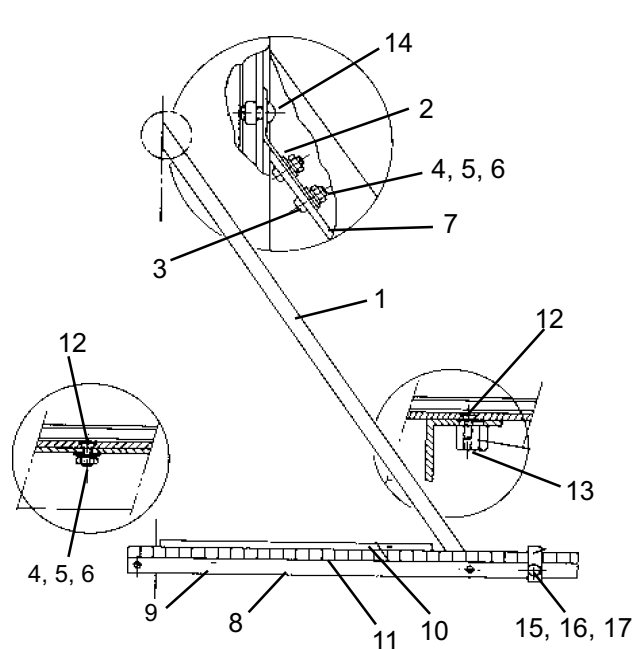

Ref.	Part No.	Description	Quantity
1	12-101	Angle Brace Assy.	1
2	12-099	Angle Brace Bracket	1
3	12-020	Pan Head Mach. Screw	2
4	12-027	Hex Nut	3
5	24-129	Lock Washer	3
6	24-130	Washer	3
7	12-098	Angle Brace	1
8	12-106	Squaring Arm Assy.	1
9	12-102	Squaring Arm	1
10	12-103	Mat Support	1
11	12-578	Scale	1
12	12-024	Flat Head Mach. Screw	2
13	12-016	Eccentric Nut	1
14	12-056	Button Head Cap Screw	1
15	12-516	Squaring Arm Stop	1
16	12-350	Plastic Knob	1
17	12-514	Key	1

## BASE EXTENSION

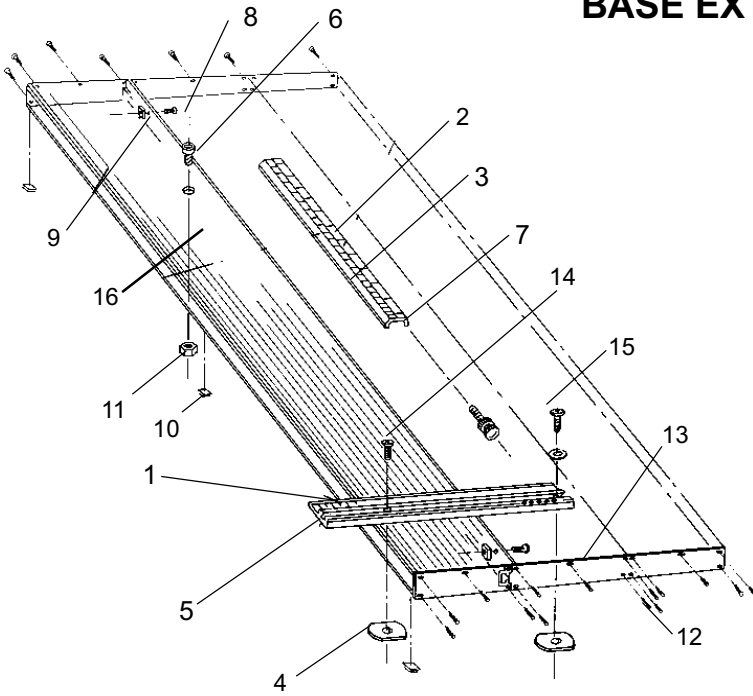

Ref.	Part No	Description	Quantity
1	12-579	Scale/Mat Guide Slide	1
2	12-581	Scale (Inch)	1
3	12-582	Scale (Metric)	1
4	12-509	Base Nut	2
5	12-520	Mat Guide Slide	1
5	12-555	Mat Guide Slide (Metric)	1
6	12-130	Threaded Insert	1
7	12-132	Upper Stop Slide/Long	1
8	12-056	Button Head Screw	2
9	12-053	Square Nut	2
10	12-035	Button	3
11	12-131	Hex Nut	1
12	12-054	End Cap Screw	10
13	12-109	End Cap	2
14	12-020	Screw	1
15	12-024	Flat Head Screw	1
16	12-594	Base Plate 40"	1
16	12-595	Base Plate 48"	1
16	12-596	Base Plate 60"	1

## MEASURING STOPS

Ref.	Part No.	Description	Quantity
1	12-556	Lower Measuring Stop Assembly	1
2	12-084	Knurled Lock Nut	2
3	12-521	Stop Screw Assembly	2
4	12-523	Clamp Bar	2
5	12-524	Grooved Pin	2
6	12-557	Upper Measuring Stop Assembly	1
7	12-095	Shoe	1
8	12-573	Scale (Inch)	1
9	12-574	Scale (Metric)	1
10	12-525	Nylon Tubing	4
11	12-597	Knob	3
12	12-527	Upper Stop Slide	1
13	12-598	Spring Button Assembly	1

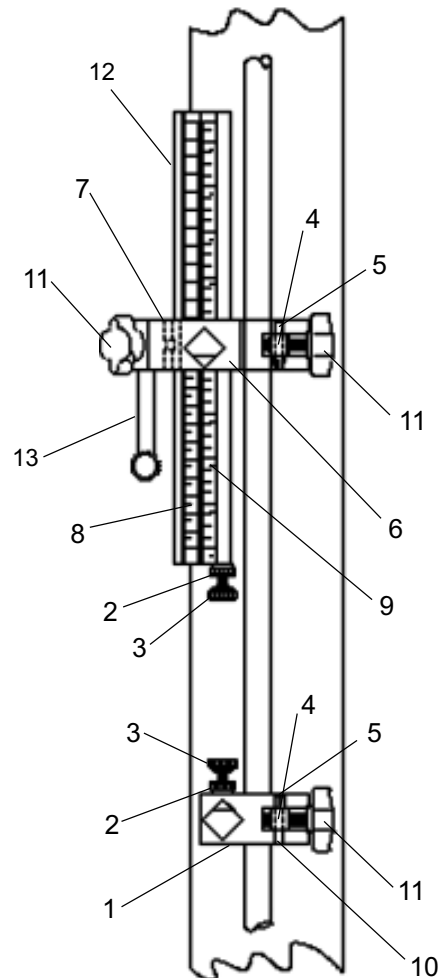



## ANGLE MAT GUIDE

Ref.	Part No.	Description	Quantity
1	12-136	Housing	1
2	12-137	Disc	2
3	12-138	Angle Arm-Upper	1
4	12-139	Angle Arm-Lower	1
5	12-140	Angle Locking Knob	1
6	12-141	Locking Knob	1
7	12-575	Label-Upper	1
8	12-577	Label-Lower	1
9	12-144	Flat Head Mach. Screw	2
10	12-145	Nylon Washer	1

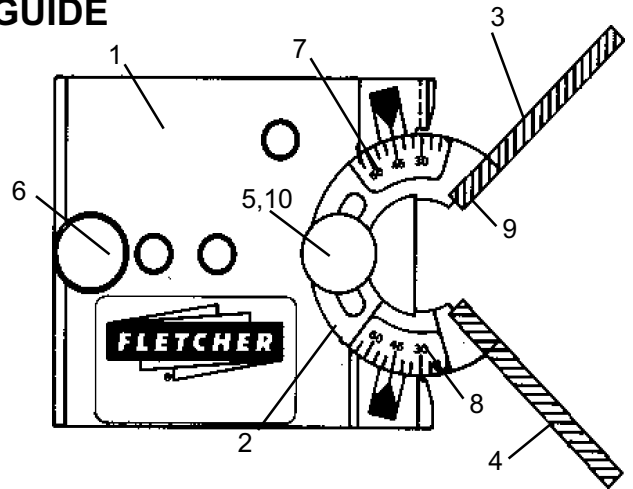

## DUST COVER

Part No.	Description	Quantity
04-644	40" (1m) Dust Cover	1
04-640	48" (1.2m) Dust Cover	1
04-645	60" (1.5m) Dust Cover	1



## CLAMP LIFTERS

Part No.	Description	Quantity
04-631	Mat Clamp Lifters	2

